

IAG Bronco Rear Mud Flaps

For 2021+ Bronco





IAG-BDY-F1303 IAG Bronco Rear Mud Flaps For 2021+ Bronco

Congratulations on the purchase of your IAG Bronco Rear Mud Flaps, and thank you for choosing IAG Off Road! These instructions are intended for users with basic mechanical skills. Professional installation is not required.

Installation video can be found on our website, or by using the the following QR code.

Scan QR code for instruction video.

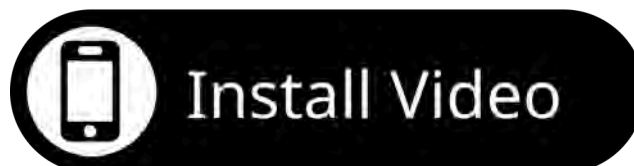



- 1** Left Rear Mud Flap
- 2** Right Rear Mud Flap
- 3** Slider Bracket
(Passenger side)
- 4** Slider Bracket
(Driver Side)
- 5** (X2) Clip Nuts
- 6** (X10) 5mm Allen bolts
(X4) 10mm nuts
(X14) Washers

Tools needed:

10mm, 13mm, 15mm, 3/8 Sockets. 13mm Wrench, 5mm Allen wrench
Pocket screwdriver and trim pry tool. Razor Blade.

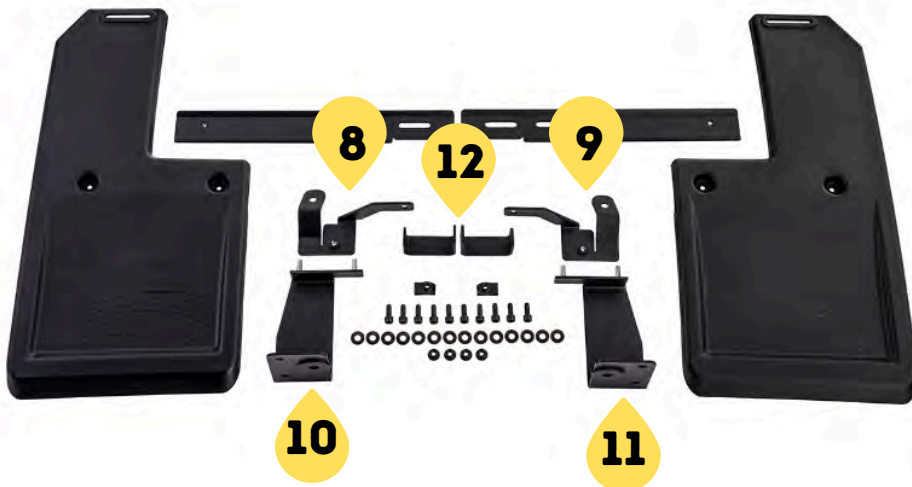

- 8** Upper Bracket
(Passenger side)
- 9** Upper Bracket
(Driver side)
- 10** Lower Bracket
(Driver Side)
- 11** Lower Bracket
(Passenger side)
- 12** (X2) Spacer Bracket



Step 1

Remove the rear fender flare from the drivers side.

Rotate the locking tabs on the inside of the fender flare 90° to disengage the tabs.



Step 1 pt. 2

Pull the fender flare away from the vehicle using even force, and set fender flare aside.



Step 2

Remove shown 10mm bolt from the fender.



Step 3

Remove shown push clip from fender liner and fold fender liner aside.



Step 4

Install the clip nut onto the fender as shown.

Unfold the fender liner.



Step 5

Prepare the Upper Bracket for the drivers side, and a 5mm Allen bolt.





Step 6

Install the bracket onto the fender.

Reinstall the factory 10mm bolt, and install the provided 5mm Allen bolt with a washer.

Tighten the bolts.

Plastic Frame Rear Bumper

For vehicles equipped with a plastic rear bumper, (15mm and 13mm bolt) **continue to Step 7 (Plastic Bumper)**.

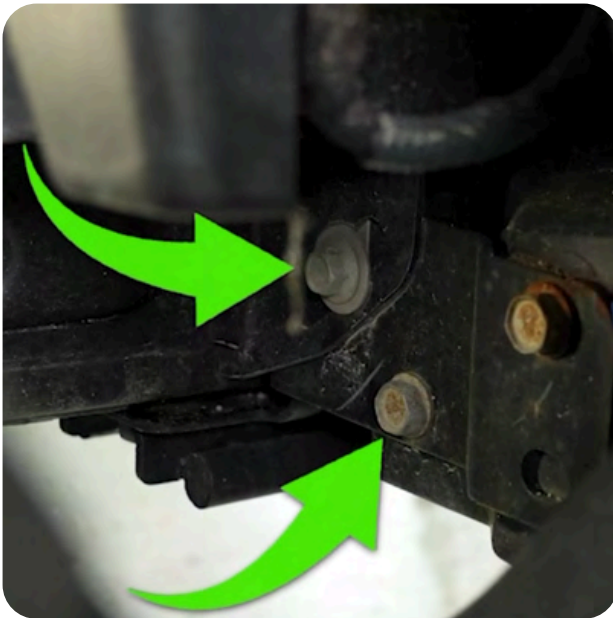

Metal Frame Rear Bumper

For vehicles equipped with a metal rear bumper, (two 13mm bolts) **skip to Step 8 (Metal Bumper)**.



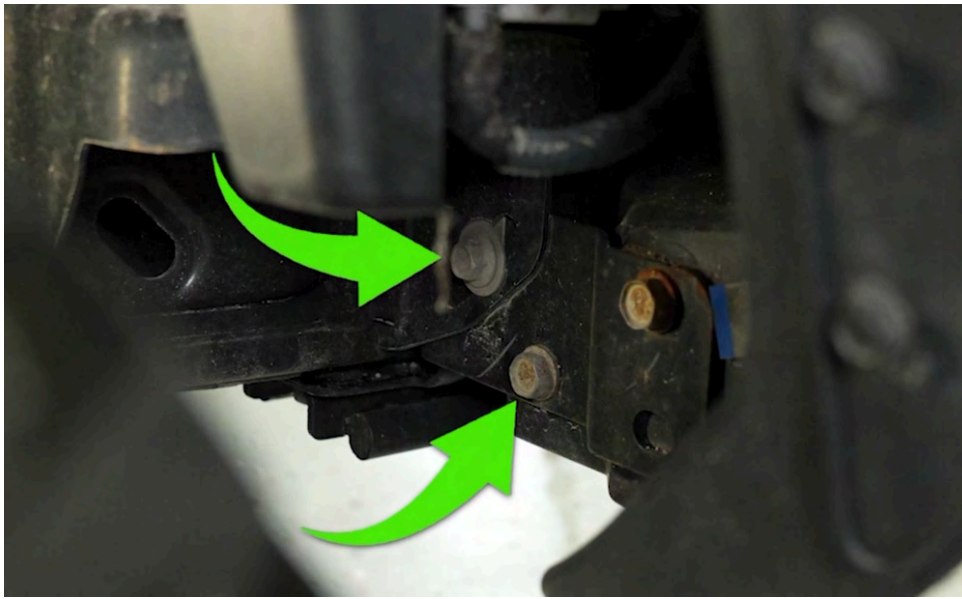

Step 7 (Plastic Bumper)

Remove the 15mm and 13mm bolts from the bumper



Step 7 pt. 2

Prepare the Lower Bracket for the drivers side.

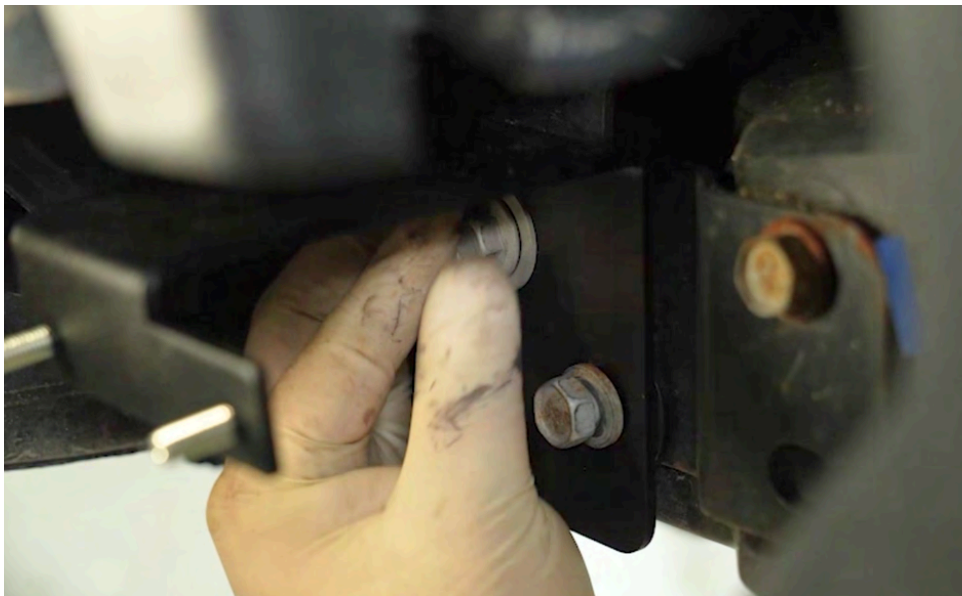

Step 7 pt. 3

Install the Lower Bracket onto the bumper, and reinstall factory bolts.

Tighten the bolts.

Skip to step 18.

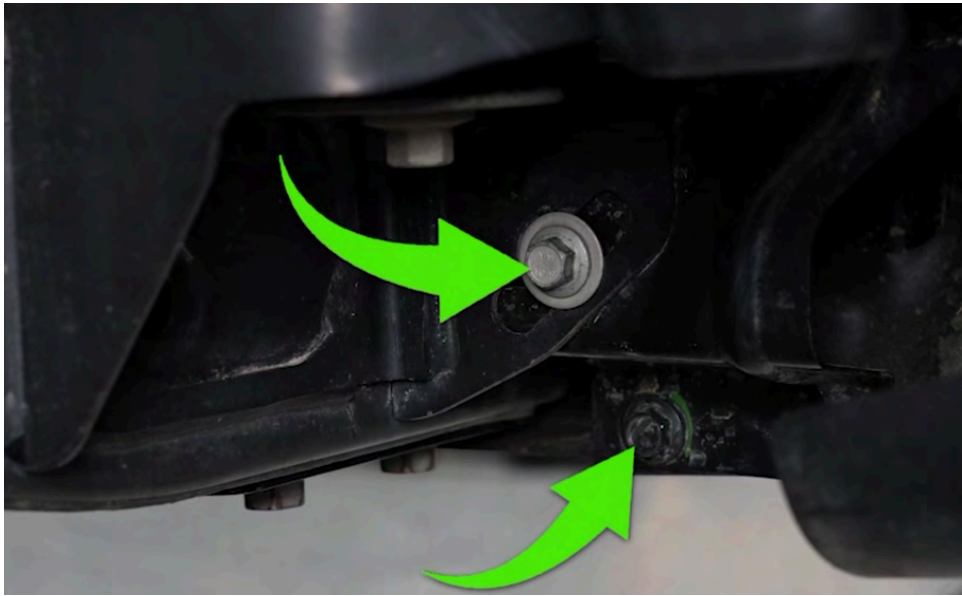

Step 8 (Metal Bumper)

Remove the two 13mm bolts from the bumper.



Step 8 pt. 2

Prepare the Rear Lower Bracket for the drivers side.

10



Step 8 pt. 3

Install the Lower Bracket onto the bumper, reinstall one of the factory 13mm bolts but do not tighten.

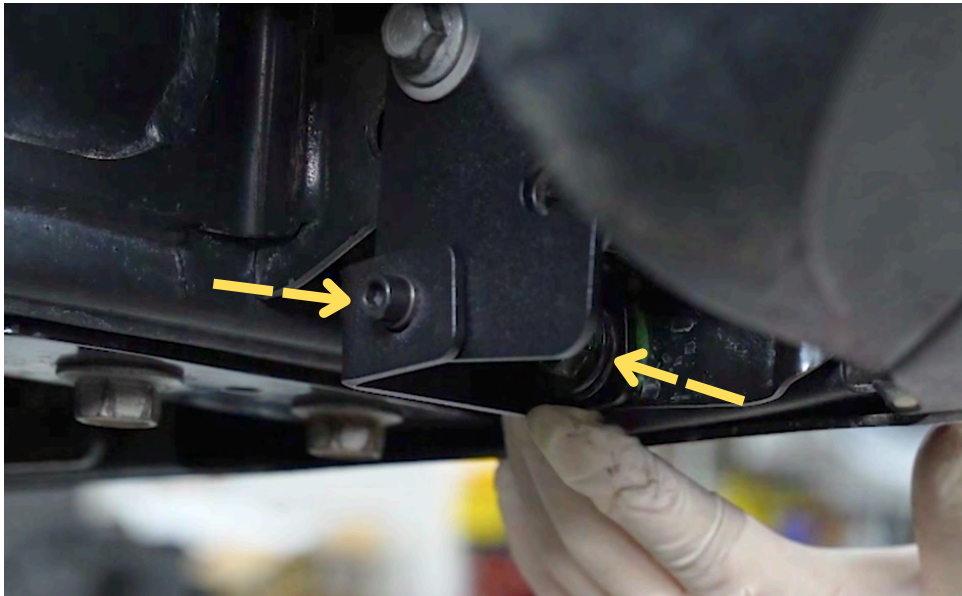

Step 8 pt. 4

Prepare the Spacer Bracket and a 5mm Allen bolt.

Install the Spacer Bracket onto the bumper, install the factory 13mm bolt, and the 5mm Allen Bolt with washer.

12

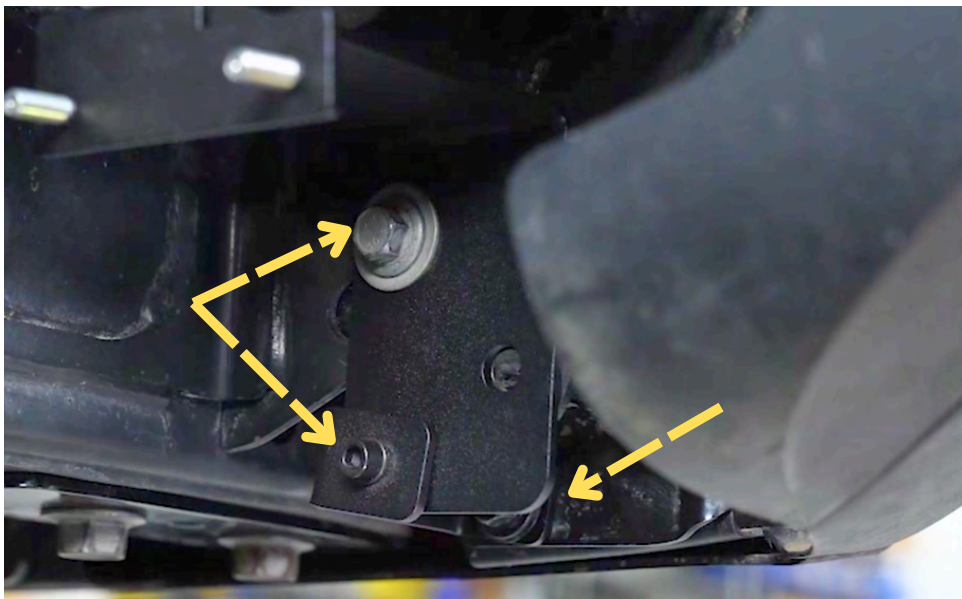

Step 8 pt. 5

Tighten the three bolts.



Step 9

Prepare the LR Mud Flap, driver side Slider Bracket, and two 5mm Allen bolts.

1



4





Step 9 pt. 2

Install the Slider Bracket onto the Mud Flap with the notch facing up.

Install the Allen bolts with washers and tighten.



Step 10

If vehicle is equipped with Bumper Flares, remove the flares.

Remove the three 3/8 screws from the flare.



Step 11

Using a razor blade, cut the excess plastic extruded from the screw holes.



Step 12

Install the Mud Flap Slider onto the studs of the Lower Bracket



Step 13

Install a 5mm Allen bolt and washer into the Mud Flap and Upper Bracket

Do not tighten.



Step 14

Install two 10mm nuts and washers onto the studs of the Lower Bracket.

Do not tighten.



Step 15

Reinstall the fender flare.

Rotate the locking tabs 90° to secure the flare.



Step 16

Adjust Mud Flap to align with fender flare.



Step 16 pt. 2

Tighten the Mud Flap hardware.

Step 17

Repeat for other side.



If you have any questions about the product or install please reach out to support@iagoffroad.com or call 410-840-3555